



CAD  
INTEROPERABILITY  
API



Embedding our API makes all current CAD formats available in your application – cost efficient and within the shortest space of time.

#### INTEROPERABILITY SOLUTIONS

Today engineering software companies and their customers are looking for new ways to read a variety of 3D CAD data formats. 3D\_Kernel\_IO is the first API with native readers based on a specialized mathematical library allowing the efficient, precise and independent access to all native and standard formats.

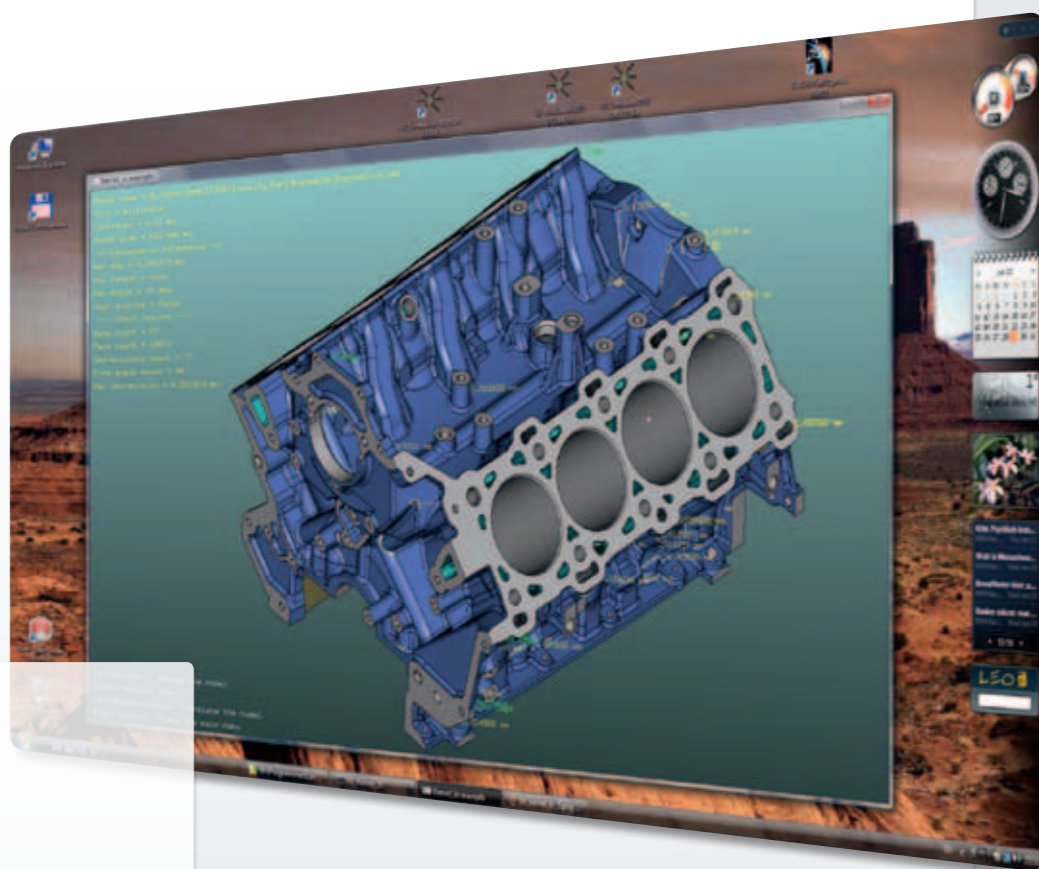

#### PROVEN TECHNOLOGY

In addition 3D\_Kernel\_IO provides unique and proven functions and modules with automatic healing, PDQ-Checker, Assembly Management, Precision Tessellation, Metafacing, Defeaturing, Model Comparison and Simplifier to extend the capabilities of your software.

#### NATIVE INTERFACES

All standard and native interfaces are developed and maintained by CoreTechnologie ensuring a guaranteed support of the newest CAD format versions. 3D\_Kernel\_IO reads assembly structure, attributes like names, curves, or layers, entities like points, B-REP solids and skins as well as tessellated models. Furthermore, features with history, PMI, attributes and metadata (e.g. DC Master, publications) are directly accessible without a CAD license or application:

- INVENTOR
- JT-Format
- XT-Format
- ACIS
- STEP AP 203/214
- IGES
- CATIA V5
- CATIA V4
- PRO/ENGINEER
- SIEMENS NX
- IDEAS NX
- SOLIDWORKS

#### ADAPTIVE CONVERSION AND HEALING

During the conversion process, the 3D Models will be adapted to the tolerance and the mathematics of the target system to provide exceptional quality. Healing functions will automatically correct failures, such as gaps, overlaps, twisted and mini-faces. Even a set of single surfaces can be sewn automatically into watertight solids with a user-defined accuracy.

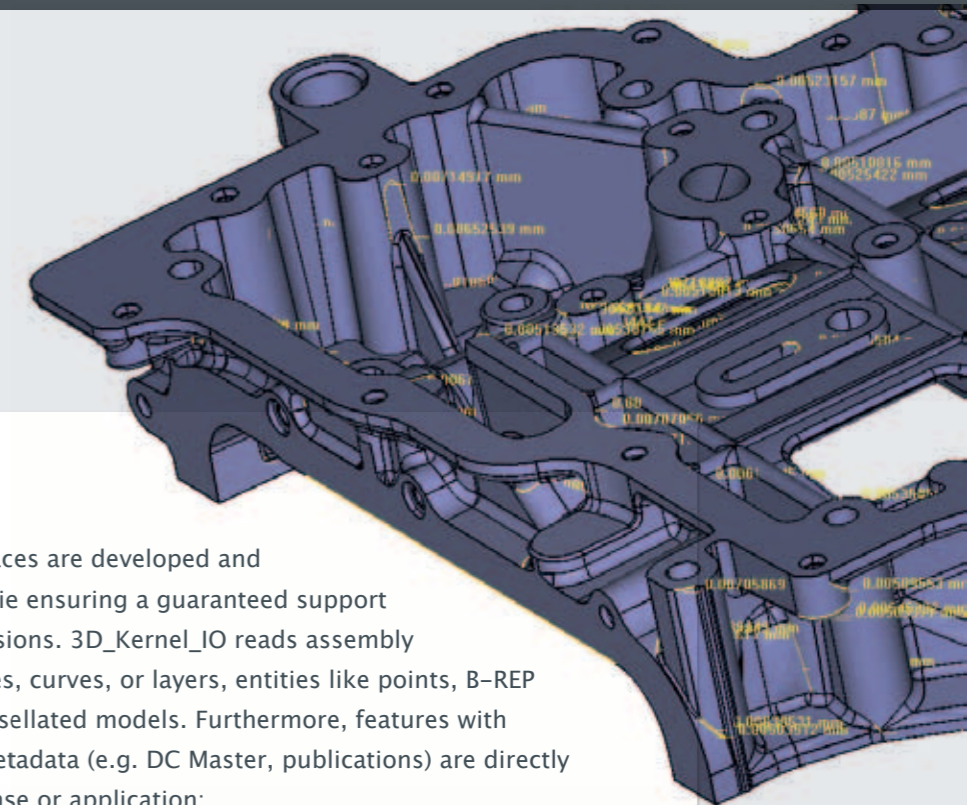

## Available on Windows, Linux, Unix and MAC for 64 and 32 Bit Platforms.

### EASY TO INTEGRATE

3D\_Kernel\_IO API is based on C++ and on the Compiler Microsoft VisualStudio.NET. The interrogation functions are standardized for all formats, allowing the access to parameters in the C++ classes. That means one integration for all formats and functions! Therefore, 3D\_Kernel\_IO can be deployed very easily and will be available in your application within the shortest time.

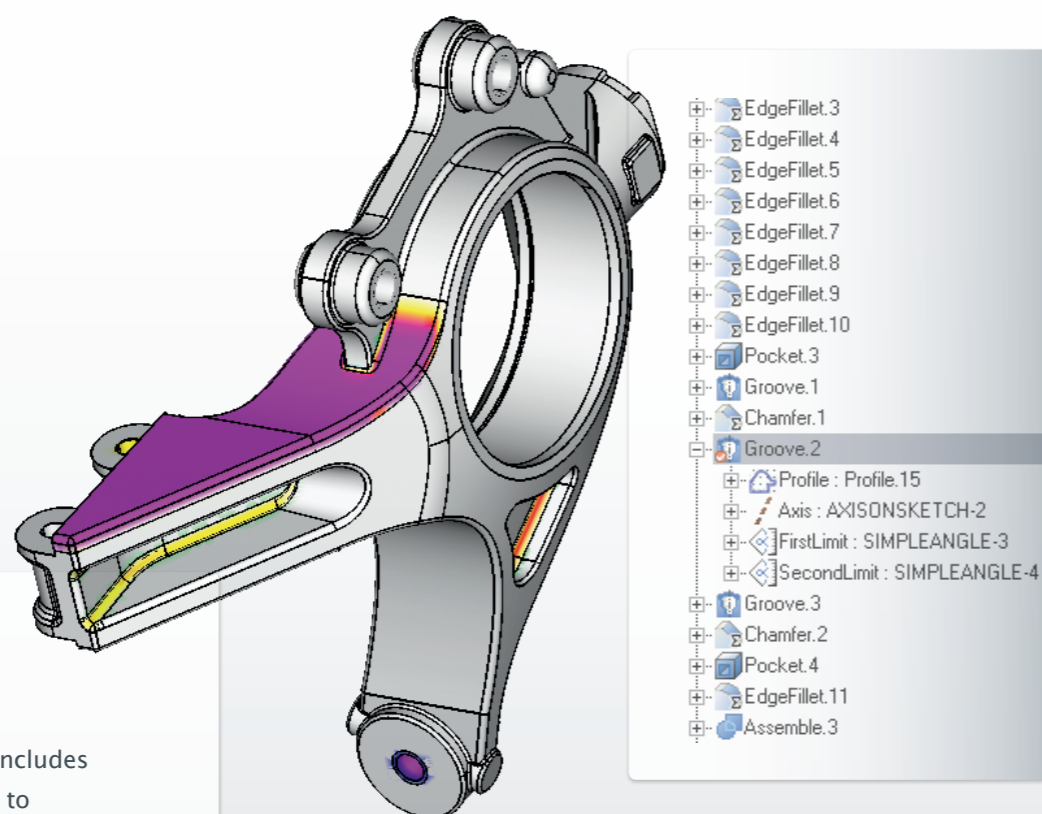

### EASY TO USE

3D\_Kernel\_IO also includes a simple to use GUI to verify the results of your integration and to try the various options and commands the API offers. It also comes with a complete documentation as well as descriptive programming samples.

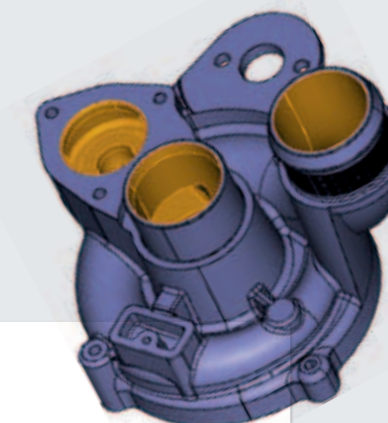

### FLEXIBLE LICENSING

3D\_KERNEL\_IO allows software editors to satisfy all their interoperability needs dealing with only one vendor, one API and one predictable and affordable annual licensing fee or per license cost. The licensing system can be adopted as open library with code protection or optional as locked API based on FlexIm License manager.

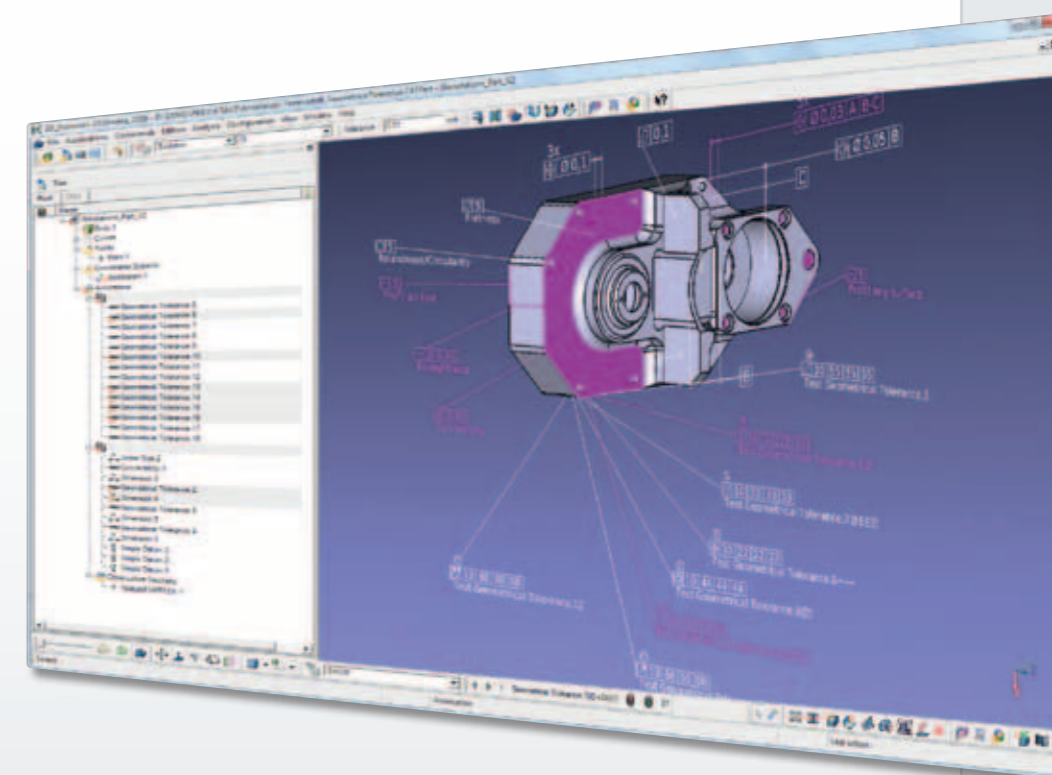

### PMI INFORMATION

3D\_Kernel\_IO native interfaces also read the PMI information like GD&T annotations, datums and text. All links to the geometry are provided; this is mandatory to use PMI in Metrology and CAM applications. Generalized interrogation functions allow an easy access to the PMI data of any CAD format providing important information for a seamless PLM process.

## Providing specific functionalities for CAD CAM CAE VR and Metrology.

### HISTORY AND FEATURES

3D\_Kernel\_IO native interfaces read feature Information and PMI of threads, holes, chamfers, fillets, patterns, drafts, pockets, extrusions and other feature types as well as assembly features. The data structure represents all feature types used by today's CAD systems. 3D\_Kernel\_IO maps the construction history and parameters directly from the binary file without requiring access to a license of the source CAD system.

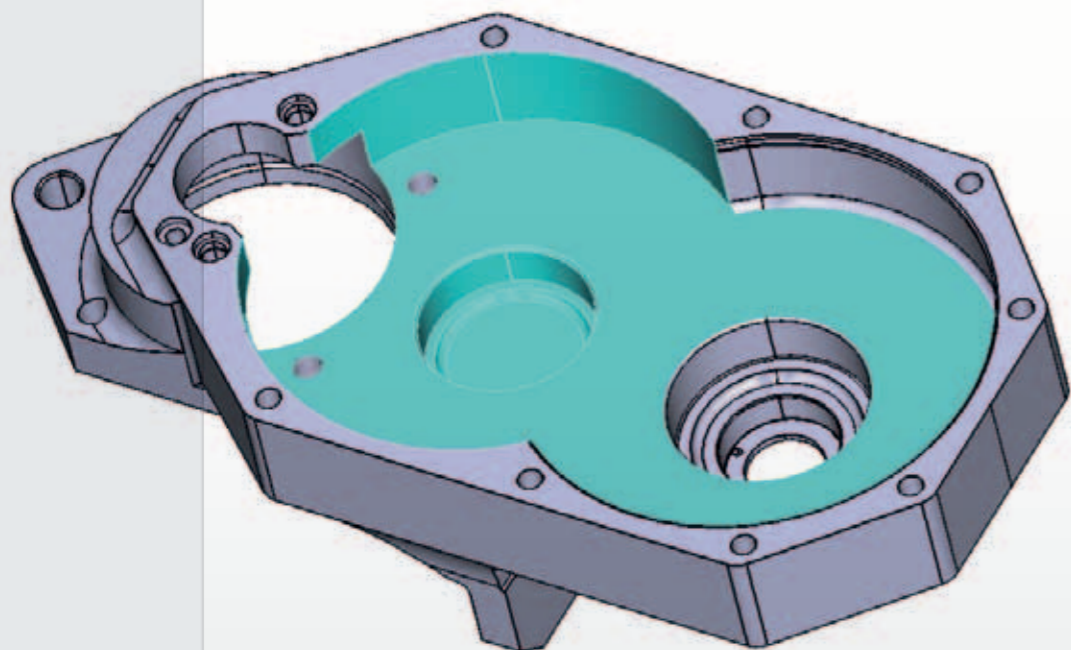

### CAM INFORMATION

The associated faces of each feature on the B-REP Model will be indicated by 3D\_Kernel\_IO and can be traced easily. Threads information is provided, which is important for annotations and PMI that reference construction elements like sketches, planes or datum axes. In addition to the Feature Recognition module extracts Feature Information from any B-REP Geometry. These information e.g. of holes and pockets can be accessed by the same interrogation functions.

### GEOMETRIC COMPARISON

3D\_Kernel\_IO Compare indicates differences between bodies, assemblies and PMI information. Assemblies with different naming and/or structure will also be analyzed. B-REP and tessellated models can be compared.

### BOUNDING GEOMETRIES

The Simplifier module generates bounding geometry of individual parts and assemblies. These simplified models are ideal for use in digital mock-ups and factory simulation. The Simplifier function creates exact envelopes of the original parts and assemblies. This function removes the interior of a geometry providing a perfect lightweight solid bounding geometry easy to handle for subsequent operations.

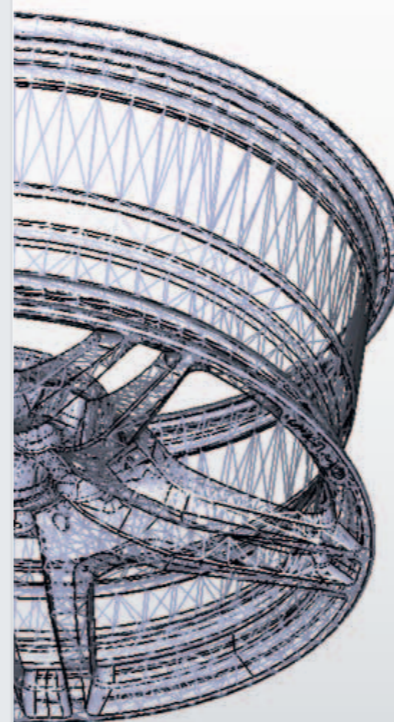

### TESSELLATION

The accurate and fast tessellation of 3D models as well as healing functions for triangulated models are optimizing CAD data for digital mockups, virtual reality, and high-end rendering. Parameters for maximum chord deviation, triangle size, and the angle between adjacent triangles are used for B-REPS or the recalculation of triangulated models. VRML, JT, and STL are available.

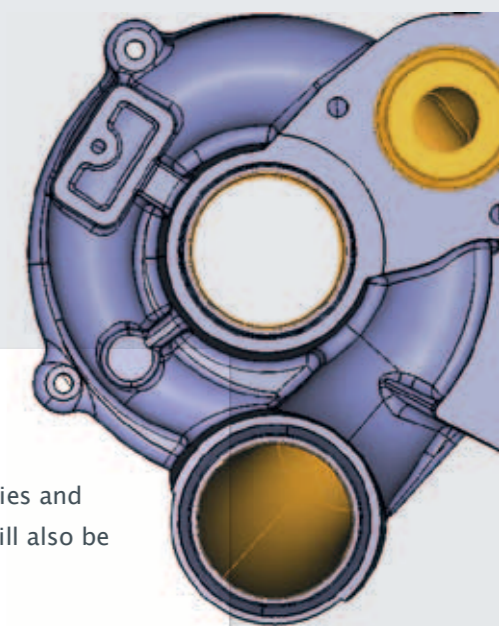



## ABOUT CORETECHNOLOGIE

Our mission is to optimize interoperability, helping organizations to efficiently share engineering data in the PLM process. Founded in 1998, CT CoreTechnologie consistently presents the most innovative developments and has shown an outstanding performance.

In the market we are recognized as reliable and fast reacting partner offering a wide range of sophisticated interoperability software solutions.

3D\_Kernel\_IO is also the core of our 3D\_Evolution® suite which is the first-choice conversion tool of leading technology companies developing complex products in the automotive, aerospace, mechanical engineering and consumer goods industries.

Therefore, CoreTechnologie knows what counts in the CAD interoperability business and supports your needs. We understand that sometimes small details make a big difference. This is why we are also offering tailored solutions for our OEM customers.

Based on your specifications and our outstanding experience we develop customized interfaces and functions that meet all of your requirements perfectly. Using 3D\_Kernel\_IO, you benefit from well-established and mature products as well as the entire expertise and experience of the market leader for CAD interoperability solutions.



[www.coretechnologie.com](http://www.coretechnologie.com)

CATIA® and SolidWorks® are registered Trademarks of Dassault Systèmes, SIEMENS PLM Software®, Robcad®, and Ideas® are registered Trademarks of SIEMENS, ProEngineer® is a registered Trademark of Parametric Technology Corporation

### GERMANY

CT CoreTechnologie GmbH  
Am Kreuzberg 7  
D-63776 Mömbris  
Tel: +49 (0) 6029 98 999 10  
[info@de.coretechnologie.com](mailto:info@de.coretechnologie.com)

### FRANCE

CT CoreTechnologie Vente  
Parc Techsud  
12 rue du Professeur Jean Bernard  
F-69007 Lyon  
Tel: +33 (0) 4 78 61 79 42  
[info@fr.coretechnologie.com](mailto:info@fr.coretechnologie.com)

### JAPAN

CT CoreTechnologie Japan Office  
〒100-0006  
Tokyo Chiyoda-ku Yurakucho  
1-6-3 Hibiya Eisen Bldg.  
Tel: +81 (0) 3 3591 2619  
[info@jp.coretechnologie.com](mailto:info@jp.coretechnologie.com)

### U.S.A.

CT CoreTechnologies Inc.  
63 Dixie Hwy  
Rossford, OH 43460 U.S.A.  
Tel: (419) 662 7700  
[info@coretechnologies-inc.com](mailto:info@coretechnologies-inc.com)